

# A Portable Differential Proton Magnetometer

Vincas P. Steponaitis

University of Michigan

Jeffrey P. Brain

Harvard University

*The principle, construction, and operation of a portable proton magnetometer is described. The low cost of this instrument is within the means of the most modest archaeological budget. Its wide applicability to a variety of situations renders it a useful tool in many archaeological endeavors.*

## Introduction

The proton magnetometer is an instrument of great value to archaeologists, particularly for prehistorians, in its ability to locate buried non-metallic cultural features such as hearths, burned floors, trash pits, and burials. Moreover, it is highly sensitive to the presence of iron, making it quite useful in detecting features at historical sites as well. While the magnetometer is by no means foolproof, it can greatly assist the archaeologist in locating those areas within a site which are most likely to produce useful data. Hence, it serves to enlarge the amount of relevant information recovered per unit of dirt moved. The advantages of such increased efficiency should be self-evident, particularly at a time when archaeologists are commonly faced with the dilemma of having to accomplish specific research objectives within the constraints of very limited budgets and restricted field schedules.

Despite its wide capabilities, the magnetometer has not been employed as often as its utility would warrant. There are several reasons for this shortcoming, but the chief problem seems to be that the prices of commercially available magnetometers have been prohibitive, generally in the range of \$2,000-3,000 and up. These commercial instruments offer a very high sensitivity coupled with a digital readout that allows the user to make a "magnetic map" of the site being investigated. The electronic complexity required to produce such an accurate quantitative output is considerable, hence the high price of the instruments. Much recent literature has dwelt on the use of these digital devices, and on the formulation of highly sophisticated techniques (usually in-

volving computer analysis) by which magnetic survey data can be more accurately interpreted.<sup>1</sup> Such developments have certainly provided us with some powerful research tools, but these are tools that not all archaeologists can afford, either in terms of equipment cost or in technical expertise.

It is unfortunate that the recent preoccupation in the literature with expensive hardware has tended to obscure the fact that a much simpler device, the differential proton magnetometer (or proton gradiometer, as it is sometimes called), is adequate in most applications. The simplicity and low cost of the unit are achieved by making the output non-quantitative: it detects archaeological features by means of a qualitative change in the tone of an audio signal which is monitored by the operator on a set of headphones. The device is light in weight, fully portable, and can easily be operated by a single individual. It is somewhat less sensitive than its highly sophisticated cousins, and cannot be used to map with accuracy the configuration of buried features. It can, however, *locate* such features just as effectively as its more expensive counterparts, and can cover a given area of ground much more rapidly.

A differential proton magnetometer like the one described above can easily be built at a material cost of less than \$100. The rest of this paper will be devoted to a description of the principle, construction, and operation

1. See, for example, R. E. Linington, "Techniques Used in Archaeological Field Surveys," in *The Impact of the Natural Sciences on Archaeology*, T. E. Allibone et al, eds. (London 1970) 89-108; and I. Scollar "Magnetic Methods of Archaeological Prospecting: Advances in Instrumentation and Evaluation Techniques," in *ibid.*, pp. 109-119.

of such a device, which has been tested in a field situation, and shown to be reliable and highly effective. In making available these plans, it is our hope that more of our colleagues will now find it within their means to acquire this useful instrument and apply it in their research.

### Basic Principles

Before we present the design of our instrument, it is appropriate to review here the basic principles by which the differential proton magnetometer operates. The discussion will be deliberately brief and non-technical; a more comprehensive treatment of the subject can be found elsewhere.<sup>2</sup>

### Magnetic Anomalies

Essentially, the differential magnetometer is a device that reacts to minute changes in the earth's magnetic field. Its effectiveness as a detector stems from the fact that certain types of buried cultural remains can, in their immediate vicinity, slightly affect the intensity of the earth's field. These small, localized variations in intensity are called magnetic anomalies. Anomalies strong enough to be picked up by the differential magnetometer are usually caused by one or more of the following kinds of cultural remains.

- I) Iron or other ferrous metals.
- II) Burned features, such as hearths, houses, kilns, etc.; also concentrations of ash, daub, or other baked clay objects.
- III) Features which are characterized by midden soil intruding into a matrix of lesser organic content, or vice versa. Specifically, these can take the form of midden-filled pits or wall trenches, or in the opposite situation, accumulations of sterile earth or stone imbedded in a deposit of midden (for example, walls or foundations).

The magnetometer is by far the most sensitive to iron. A barbed wire fence, for example, can easily be picked up from as much as five feet away. At the same time, it is important to realize that the instrument is very selective in this respect: the magnetometer *does not* react to non-ferrous metals.

The anomalies caused by non-metallic features are usually substantially weaker than those caused by iron. Burned areas are readily detectable due to the property of thermo-remanent magnetism. Detection of features in

the third category, however, and of concentrations of daub and ash is a considerably more uncertain proposition. Such anomalies are caused by the juxtaposition of soils with highly contrasting magnetic properties. The degree to which such features are detectable depends not only on their size and their depth, but also on their physical structure, and, most importantly, on the magnetic properties of the soils involved.<sup>3</sup> In general, the strength of such an anomaly is directly related to the degree of contrast between the organic content of the feature itself and that of its surrounding matrix. Thus, for example, a large, midden-filled pit lying in a matrix of subsoil would almost certainly be detected, while a midden-filled pit in a matrix of midden would probably be missed. Ash and burned clay, apart from thermo-remanent magnetism, also have magnetic properties that contrast markedly from those of sterile subsoil.

In addition to those of cultural origin, anomalies caused by geological features can occur as well. For example, boulders of certain igneous (and metamorphic) rocks contain sufficient thermo-remanent magnetism to be detected by the magnetometer. This property is particularly associated with volcanics of the tertiary period and later, less so with granites and older volcanics.<sup>4</sup> Clearly, the presence of geological anomalies can mislead the archaeologist searching for cultural remains. Any natural deposit in which large igneous rocks are common will render magnetometer survey extremely difficult, in that a large number of spurious readings can be expected. It is absolutely necessary, therefore, for the archaeologist to be familiar with the geology of the area under study in order to assess the likelihood of running into this impediment.

### Detection

The basic element of all proton magnetometers is the detector coil, which consists of a coil of wire wrapped around a plastic bottle, or some other suitable container. The bottle is filled with distilled water, or some other fluid rich in hydrogen nuclei (that is, protons).

In order to understand how the detector coil operates, we must first briefly discuss the physical principle of *proton free-precession*. This principle refers to the fact that protons under the influence of the earth's magnetic field precess around an axis parallel to that field. This precession is exactly analogous to the slow gyration of a spinning top. In the case of protons, the frequency of gyration (that is, the number of gyrations per second) is directly related to the intensity of the earth's magnetic field. The stronger the field, the higher the frequency of precession.

3. Tite, op. cit. (in note 2) 11-15.

4. Aitken, op. cit. (in note 2) 39.

2. Martin J. Aitken, *Physics and Archaeology* (New York 1961); "Magnetic Location," in *Science in Archaeology*, D. Brothwell and E. Higgs, eds. (New York 1970) 681-694; M. S. Tite, *Methods of Physical Examination in Archaeology* (New York 1972) 9-25.

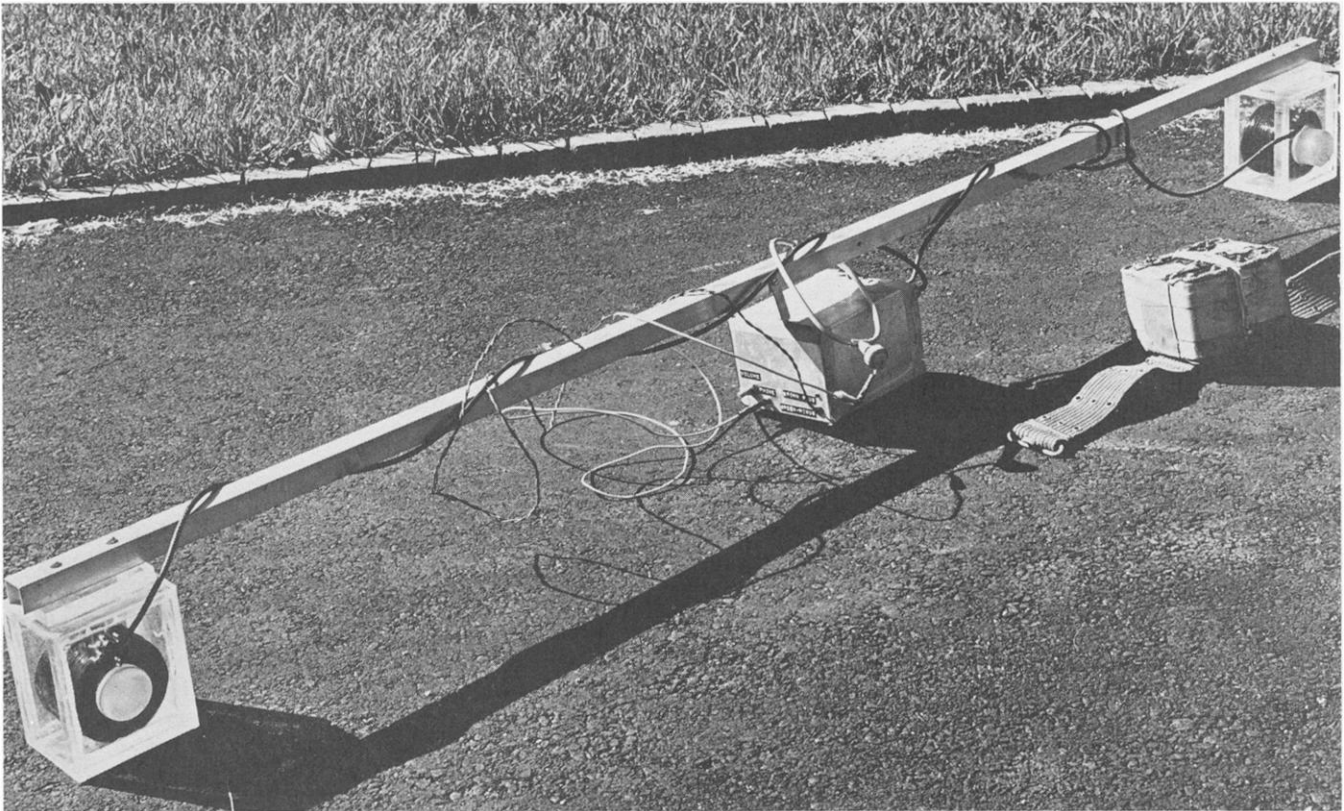

Figure 1. The portable differential proton magnetometer, fully assembled and ready for use. Photo by Hillel Burger.

Each proton can in essence be visualized as a small bar magnet. As each one precesses, its tiny magnetic field is capable of generating an infinitesimally small voltage in the surrounding coil. Under normal circumstances, all the protons in the bottle precess at the same rate, yet because their gyrations are out of phase with respect to each other, their individual effects interfere in such a way as to produce no net voltage in the coil. In order for the effects of this precession to be measurable, the protons must be made to act in phase, so that the miniscule voltages induced by the individual protons add together, rather than cancel out.

It is for this reason that the protons must be subjected to a strong polarizing field before each measurement. An electric current (approx. one ampere) is passed through the coil, setting up a strong magnetic field within the bottle. Because this field is much more intense than that of the earth, the protons become aligned along its lines of force. When the current in the coil is abruptly cut off, the protons cease to be constrained by the polarizing field and once again begin to precess around the earth's magnetic field. Having initially been polarized, the protons gyrate in phase and a small, yet appreciable signal is induced in the detector coil, having an amplitude on the order of a millionth of a volt. The fre-

quency of this signal is equal to the frequency of proton precession, and hence is proportional to the local intensity of the earth's magnetic field.

Once the influence of the polarizing current has disappeared, however, the protons do not long remain in phase. Various internal effects cause the phase coherence of the protons gradually to die out and disappear. As a consequence, the induced signal also "decays," and slowly decreases to zero. The time it takes for the signal to disappear entirely is comparable to a value termed the *relaxation time*. Relaxation time varies from one fluid to the next, being about three seconds for distilled water. When the protons get out of phase, they must again be polarized before another measurement can be made.

The differential magnetometer to be described in this paper basically consists of nothing more than two detector coils, a switching circuit, a high-gain amplifier, and a set of headphones. The two coils are mounted at either end of a six-foot long horizontal staff, and the circuitry is mounted in between (FIG. 1). The switching circuit controls the timing in a cycle whereby a three second *polarization period* continually alternates with a three-second precession period: a polarizing field is applied to both bottles simultaneously and then is cut off, allowing

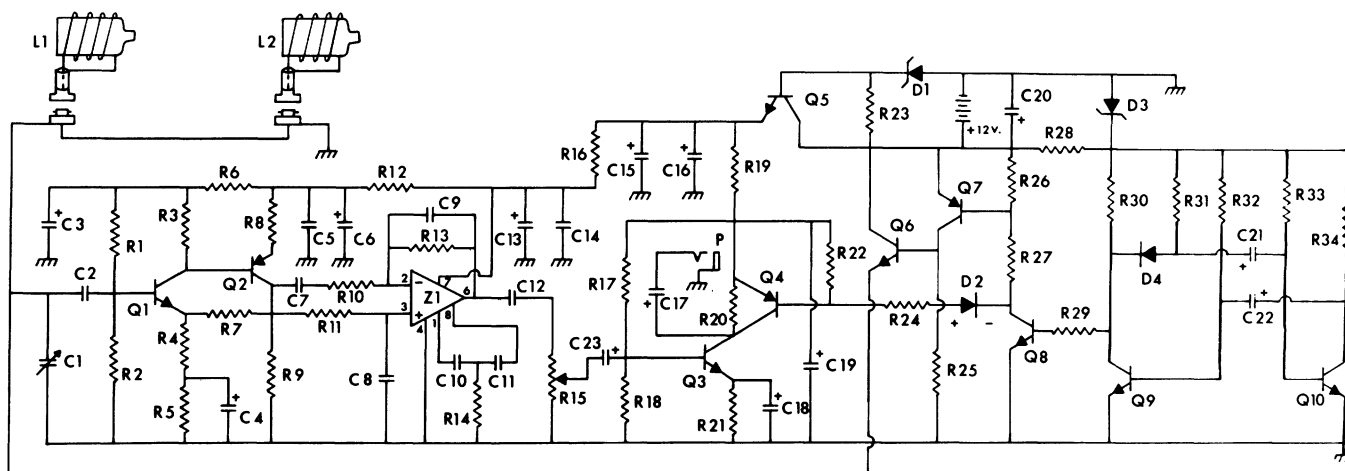

Figure 2. Schematic diagram of the portable differential proton magnetometer.

the protons to precess, and causing a precession signal to be induced in each of the coils. These signals are added together, and then amplified so that they can be heard through the headphones.

If an area being tested has a constant magnetic field, then the precession frequency induced in each of the coils is the same. When the two identical signals are added together, the operator hears a steady tone which gradually decreases in amplitude as the protons get out of phase, and disappears within three seconds.

In the presence of an anomaly, however, a totally different kind of tone is heard. Because the magnetic field at each coil is not the same, the protons in each precess at different rates, and signals of different frequency are produced. As these signals are added together, they interfere with each other: the operator hears a wavering tone, increasing and decreasing in amplitude until it finally dies out. The peaks in amplitude are called *beats*, and the rate at which they occur is called the *beat frequency*. The beat frequency is equal to the difference between the two signal frequencies. Clearly, then, the beat frequency is directly related to the degree of difference between the magnetic field intensities at each of the two coils. The more beats are heard per unit time, the stronger is the magnetic anomaly causing them.

### Construction

The design presented here is new. Its development was undertaken for the simple reason that other designs we found in the literature were inadequate for our purposes. Some designs were not described in enough detail; others specified components which were either outdated or not available in this country. The instru-

ment described below is comparable in effectiveness to those previously published. It incorporates various aspects of the other designs, but it is put together of components more readily available. Particularly valuable as sources of basic design ideas were articles by Aitken<sup>5</sup> and Harknett.<sup>6</sup>

### Circuitry

The circuitry in this unit is not especially complicated, and can easily be assembled by any competent electronics technician, or even by a reasonably proficient amateur. The schematic diagram is illustrated in Figure 2. The parts list and technical description are presented in Table 1 and the Appendix respectively.

The construction of this circuit is reasonably straightforward, but a few constraints are recommended. Ceramic capacitors should not be used, as they tend to be highly microphonic. Components made of ferrous metal should also be avoided if at all possible. The latter is not to be taken as an absolute restriction, however, because the circuitry is mounted in a position equidistant from the two detector coils, where very small amounts of iron will not significantly affect the performance of the instrument. Aluminum sockets should be used for the cables leading to the coils.

The headphone used with this unit is a standard crystal headset. In order to prevent oscillation in the output, the wires leading to the headset should either be encased in a grounded shielding braid, or be replaced with a coaxial cable. Care should be taken to ensure that the earphone is electronically insulated from the

5. Aitken, op. cit. (in note 2) 52-58.

6. M. R. Harknett, "A Proton Magnetometer with Solid State Switching," *Archaeometry* 11 (1969) 173-177.

Table 1. Parts list for the circuit of the portable differential proton magnetometer illustrated in Figure 2.

C1	Tuning capacitor	C23	4.7 mf./10v.	Q6	2N5190 (with heat sink)	R16	200
C2	0.0022 mf.			Q7	2N2907A	R17	39k
C3	22 mf./15v.			Q8	2N5133	R18	20k
C4	0.47 mf./15v.			Q9	2N5133	R19	100
C5	1 mf.	D1	1N5235/6.8v.	Q10	2N5133	R20	5k
C6	22 mf./15v.	D2	FD777			R21	3.3k
C7	0.047 mf.	D3	1N754A/6.8v.			R22	33k
C8	0.068 mf.	D4	1N914	R1	110k	R23	1k
C9	27pf.			R2	150k	R24	10k
C10	27pf.			R3	30k	R25	1k
C11	27pf.	L1	.075h (detector coil)	R4	120	R26	4.7k
C12	0.022 mf.	L2	.075h (detector coil)	R5	100k	R27	3.9k
C13	22 mf./15v.			R6	1k	R28	620
C14	1 mf.			R7	13k	R29	100k
C15	100 mf./25v.	P	phone jack socket	R8	15	R30	15k
C16	15 mf./20v.			R9	5.6k	R31	10k
C17	4.7 mf./35v.			R10	2k	R32	100k
C18	6.8 mf./35v.	Q1	SE4021	R11	2k	R33	100k
C19	100 mf./25v.	Q2	2N4355	R12	360	R34	5.6k
C20	30 mf./15v.	Q3	2N5133	R13	2.2m		
C21	30 mf./15v.	Q4	2N3906	R14	10k		
C22	30 mf./15v.	Q5	2N5133	R15	5k pot.	Z1	301A

operator's body, as even a tiny unwanted current from headset to ground (that is, through the operator's body) can interfere with the proper functioning of the circuit.

The completed circuit can be accommodated in an aluminum minibox. Mounted externally on the minibox should be: two aluminum coaxial cable sockets (one of which must be floated, that is, insulated from the minibox itself), a plug for the headset jack, a volume control (R15), a plug for the cable that leads to the batteries, and (if desired) a variable tuning capacitor (C1). The circuit diagram does not incorporate an on-off switch, so the battery must be mechanically disconnected when the unit is not in use. There is, of course, nothing that precludes the builder from installing such a switch if it is found to be more convenient.

#### Detector Coils

As long as the electronic properties of the detector coils fall within reasonable bounds, the actual details of construction are for the most part quite flexible. There are two critical conditions, however, that must be taken into account. 1) The coils must be waterproof; even small amounts of moisture in the windings of a coil can destroy its sensitivity. 2) There must be no ferrous metal anywhere in the immediate vicinity of the detectors. If bolts are to be used in construction or mounting, both aluminum and plastics are suitable. Brass should be

avoided as it may sometimes contain ferrous impurities.

The coils used in our prototype model were constructed in the following manner: the core consisted of a six-ounce polythene bottle 1.85 inches in diameter (available from any chemists' supplier). Two plexiglass endplates (4 in. x 6 in. x  $\frac{3}{8}$  in.) were machined with holes of the same diameter as the bottle. These endplates were then slid onto the bottle and cemented in place, 2 inches apart. The coil itself was pile wound (layer winding is not necessary) with 3 lbs. (945 ft.; approx. 1300-1400 turns) of #20 AWG enamelled copper wire. The leads of the coil were soldered to a coaxial cable, which passed in snugly through a hole drilled in one of the endplates. The coil was then entirely boxed in with plexiglass, the pieces being attached with cement (FIG. 3). All seams and cracks were sealed to make the coil fully waterproof. Finally, an additional piece of  $\frac{3}{8}$ -inch plexiglass was cemented to the top of the coil assembly. Into this piece were drilled two holes, which were then tapped to receive the aluminum bolts which secured the coil assembly to the frame.

Both coils should be made identically. That is, they should be wound in the same direction and their ends should be attached to the coaxial cable in the same order. This is important because the wiring of the coaxial cable sockets, as shown in the schematic diagram, is such that the coils, when plugged into the circuit, are

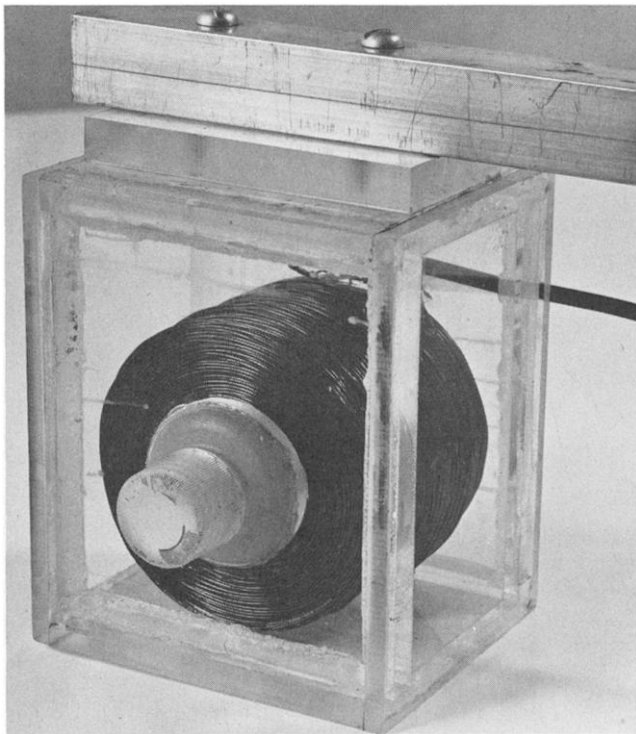

Figure 3. Closeup of detector coil. Photo by Hillel Burger.



Figure 4. Operation of the portable magnetometer. Photo by Hillel Burger.

connected electrically in opposition to each other. The advantage of this arrangement is that it serves to minimize external interference by causing most of the ambient electromagnetic pickup to cancel out.

#### *Final Assembly*

The final assembly involves mounting the circuit box and both coils to a frame. There are, of course, innumerable ways in which this can be done. The distance between the coils is not critical, and can vary anywhere from five to 10 feet. Similarly, the batteries can be carried separately, or they can be attached to the frame. The frame itself can be constructed of aluminum, wood, or plastic, but should not be made of ferrous metal. Moreover, the coils must be oriented so that their axes are perpendicular to that of the frame.

Given these constraints, our prototype (see FIG. 1) was constructed in the following manner. The frame consisted of a 6-ft. long, hollow aluminum rod, 1-inch square in cross-section. The coils were positioned at either end of this rod, with the capped end of each bottle pointing in the same direction, perpendicular to the rod. Each coil was mounted with two aluminum bolts, which passed down through the rod and into the tapped holes in the top of the plexiglass coil assembly. The circuit box was attached with aluminum brackets directly below the center of the frame, leaving enough space between the rod and the top of the box to allow one to use the center of the rod as a hand grip. The batteries were secured to a belt around the operator's waist (FIG. 4). Two conventional six-volt lantern batteries were used, connected in series. In order to prevent false readings, we found it necessary to remove the metal casings of the batteries. This task was easily accomplished with a can opener and a pair of pliers.

One other consideration deals with the coaxial cables which connect the coils to the circuit box. Normal cable suffers from electrostatic microphony, so that even a blade of grass rubbing up against it can cause an undesirable crackle in the earphones. This problem can be remedied by enclosing the cables in the frame to protect them from mechanical disturbance.

#### *Additional Improvements*

Having built and successfully tested our magnetometer as described above, we have become aware of a number of design changes which may well improve performance. Since we have not yet had a chance to incorporate these new features and test them ourselves, we cannot vouch for their efficacy. We have, however, decided to describe them in this section hoping that they will ultimately prove helpful.

To begin with, a number of minor changes would

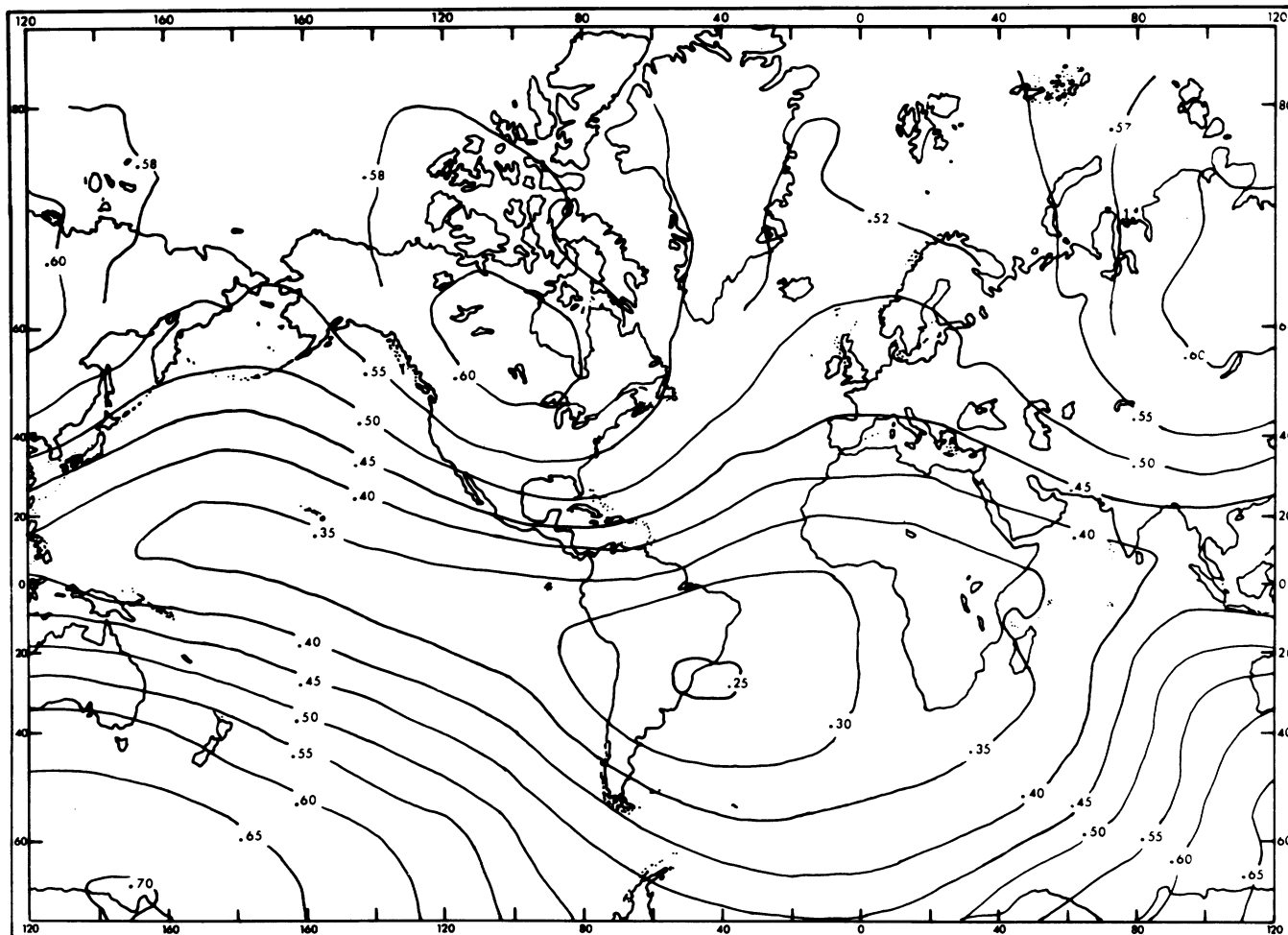

Figure 5. The geomagnetic total intensity in c.g.s. units for 1945 (After E. H. Vestine, I. Lange, L. Laporte, and W. E. Scott, *The Geomagnetic Field, Its Description and Analysis*, The Carnegie Institution of Washington Publication 580 [1947] fig. E).

probably serve to improve the signal to noise ratio in the output. The detector coils could be shielded by wrapping them in grounded copper screening or aluminum foil. Also, the external conductor in the coaxial cable leading to coil L1 (FIG. 2) is not grounded. Shielding this cable, or using shielded two-wire cable instead, would help prevent the pickup of ambient noise.

Within the circuit itself, some noise could perhaps be eliminated by adding capacitors to decrease the bandwidth of the amplifier. The present circuit has a range from 1.5 to 6 kHz. At least 3 kHz could easily be cut from the upper end of this range without impairing the magnetometer's function.

Smaller coils would significantly decrease not only the weight of the instrument, but also its cost. We have reason to believe that coils of the following dimensions would work as well as the present ones: 520 turns of #24 AWG wire wrapped along a 2.5-in. length of a bottle approximately 1.4 in. in diameter.

The fluid used to fill the detector coils of our prototype was distilled water. Replacing this water with kerosene (which has a longer relaxation time) may slightly increase the instrument's sensitivity.

## Operation

### Tuning

Before the magnetometer can be operated effectively, it must be tuned to the expected frequency of proton precession, which varies with geographical location. This frequency can be derived from the formula:

$$F_p = (4257.6) (M)$$

where  $F_p$  is the proton precession frequency, and  $M$  is the total intensity of the earth's magnetic field in c.g.s. units at the geographical region being investigated (see FIG. 5).

The appropriate value for the tuning capacitor ( $C_1$ ) is then derived as follows:

$$C = \frac{1}{(39.5)^2 (L) (F_p)^2}$$

where C is the value of the tuning capacitor (C1) in farads, and L is the combined inductance of the detector coils (twice the value of a single coil) in henrys.

Each of the detector coils in our prototype magnetometer has an inductance of 0.075 henrys when filled with water. It is highly recommended that the builder empirically measure the value of L for the coils, because variations can be expected to occur as a result of differences in construction.

Because of the low Q of the coil circuit, precise tuning is not critical. Thus, the instrument can be used over a fairly large geographical area with a fixed value for C1. If, however, it is anticipated that the instrument will be employed in several widely separated areas, then it may be preferable to install a variable capacitor instead.

#### *Field operation*

Once the magnetometer has been tuned, it is ready to be used in the field. This instrument can be expected to perform well in a wide variety of circumstances, except that it will not work effectively in urban areas or in the immediate vicinity of power lines.

When the magnetometer is operating normally, a three second polarization period continually alternates with a three second precession period. During the former, the operator hears nothing in the headphones. During the latter, a sound is heard which can be divided into two components. The first of these is a crackling and whooshing static that remains at a constant level throughout the period. This static is merely electrical "noise" and should be entirely disregarded. The second component consists of a much purer tone, which starts out at a fairly high amplitude, but gradually diminishes (in about 2 seconds) to a point where it can no longer be heard above the noise. This tone is the proton precession signal; at first, the operator may have some difficulty recognizing it with all the static present. After a bit of practice, however, the operator's ear becomes attuned to the proton signal and easily sorts it out from the background noise.

A steady decline in the proton signal's amplitude indicates a constant magnetic field, while a wavering decline, or a series of "beats," indicates the presence of an anomaly. The strength of the anomaly is proportional to the number of beats heard: the more beats, the stronger the anomaly. One exception is that in the presence of an extremely strong anomaly (almost invariably one caused by iron), the proton signal disappears almost immediately, being referred to as a "killed signal."<sup>7</sup>

7. Aitken, op. cit. (1961 in note 2) 46; Aitken, op. cit. (1970 in note 2) 687.

The sensitivity of the instrument is determined by the length of time the proton signal remains audible. The smallest anomaly detectable can be calculated with the following formula:

$$G = \frac{23.5}{P}$$

where G is the strength of the smallest detectable anomaly measured in gammas (1 gamma =  $10^{-5}$  c.g.s. units), and P is the number of seconds the proton signal remains audible.

Thus, if the proton signal lasts for two seconds (as it does in our device), the magnetometer has a maximum sensitivity of approximately 12 gammas.

Unlike some other comparable instruments, the one described here is designed to be held horizontally rather than vertically (FIG. 4). Maintaining it in this position is much less fatiguing to the operator. It must be kept in mind, however, that an anomaly can be picked up by either of the two detector coils. In practice, it is usually readily apparent which coil is actually doing the detecting, but it is nonetheless important that one be very careful in making certain, for attributing an anomaly to the wrong coil can lead to an error in location of six feet (or more, if the separation between the coils is larger). Whenever any doubt arises as to the actual location, the confusion can almost always be resolved by approaching the locus in question from a different direction. In searching for weak anomalies, or in trying to pinpoint the center of a large one, it is often helpful to keep the forward coil tilted closer to the ground, causing it to pick up the anomaly readings more strongly (FIG. 4). Generally, the magnetometer has its greatest sensitivity when the frame is oriented along a N-S axis. In order to prevent spurious readings, the operator should not have any large ferrous objects on his person. However, the small amount of iron contained in an average-sized belt buckle or in the eyelets of a pair of field boots will usually not cause any problems.

The most common problem one encounters in using the magnetometer is that the topsoil of archaeological sites is quite often littered with iron of recent origin. When this occurs, the operator is faced with a spate of unwanted readings caused by things such as beer cans, tractor bolts, and old pieces of barbed wire. In order to overcome this problem we found it helpful to use, in addition to the magnetometer, a conventional, commercially available metal detector (a "BFO"). This device was sensitive only to a limited depth, rarely able to detect anything more than a foot below the surface. Each time the magnetometer picked up an anomaly, the immediate area was checked with the BFO. If the BFO detected the presence of metal, then the magnetic anomaly was probably being caused by recent iron and could be ignored. If, however, the BFO detected



nothing, then the anomaly was probably the result of a non-metallic archaeological feature worthy of further attention (or else it was the result of iron buried deeply enough to make a recent origin unlikely).

If the procedures outlined above are followed, and special attention paid to the strictures of construction and operation that we have stressed, then a sensitive operator and experience should produce outstanding results with this modest instrument.

#### Appendix: Circuit Description

The schematic diagram presented here duplicates exactly the circuitry in our prototype unit. We are well aware that it can be improved in a number of ways, yet because we have not had the chance to test these improvements ourselves and show them to be effective, we have decided not to include them in the circuit diagram. Our design as it appears here may seem inelegant to some, but at least we can be certain that it works.

*Switching circuit.* Q9 and Q10 form a stable multivibrator controlling the "on" or "off" state of Q8. The duration of each half-cycle is determined by the time constants  $R32 \cdot C20$  and  $R33 \cdot C21$  respectively; both in this case are approximately 3 seconds. Q7 (turned "on" and "off" by Q8) drives the power transistor Q6. Q6 supplies the polarizing current to the detector coils L1 and L2.

*Amplification.* C1 forms a parallel tuned circuit with the detector coils L1 and L2, adjusted to resonate in the vicinity of the proton precession frequency. Q1 and Q2 form a low-noise high-gain preamplifier, capacitatively coupled to the op-amp Z1. R15 acts as a volume control by varying the amplitude of the signal passing from Z1 to the high-gain output amplifier Q3.

Q5, D1, and R23 form a voltage regulator which maintains a steady 6-volt supply to the amplifier.

Q4 acts to switch off the earphones during the polarization period. When Q8 is on, D2 is forward biased, and Q4 is switched on, shorting out R20 and preventing a signal from being passed to the earphones. During the precession period, Q8 is off, D2 is reverse biased, and Q4 is off and effectively out of circuit.

**Acknowledgements.** We are greatly indebted to Cecil Hayes (Rutgers University), Sam Maslak (MIT), and Jeff Millman (MIT) for generously giving their time and talents in designing the circuitry presented in this article. We would also like to thank Thomas Hart, William Herman, and Dr. Alan MacNee (University of Michigan) for their critical reading of earlier drafts. Many of their useful suggestions have been incorporated herein.

*Jeffrey P. Brain, Research Fellow at the Peabody Museum, Harvard University, received his Ph.D. from Yale University in 1969. His current research interests focus on the prehistory of the southeastern United States, and early historical contact situations throughout North America.*

*Vincas P. Steponaitis, who holds a B.A. degree from Harvard University (1974), is currently a graduate student at the Museum of Anthropology, University of Michigan, Ann Arbor. His interests include the archaeology of the Lower Mississippi Valley and the application of electronic techniques to field investigation.*